

# TYPE B

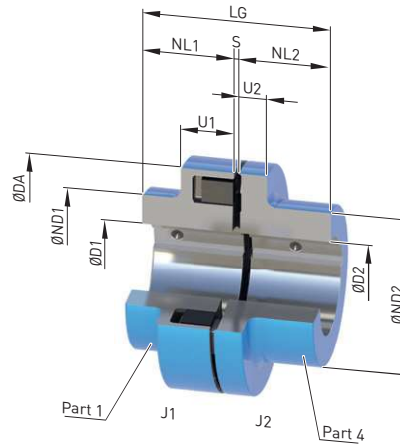

7

Size	Rated torque flexible type 80 ShoreA $T_{KN}$ Nm	Speed $n_{Kmax}$ rpm	Dimensions in mm													Mass moment of inertia $J_1/J_2$ kgm <sup>2</sup>	Article no. <sup>1)</sup>	Weight $m$ kg			
			Bore with keyway to DIN 6885-1							DA	ND1	ND2	NL1/  NL2	S	ΔS +/-				U1	U2	LG
			D1		D2		Part 40 <sup>2)</sup>														
58	28	9000	-	22	-	25	32	58	58	40	20	3	1.0	20	8	43	0.0001	2LC0170-0AA	0.4		
68	48	8400	-	28	-	30	40	68	68	50	20	3	1.0	20	8	43	0.0002	2LC0170-1AA	0.6		
80	85	7200	-	38	-	42	48	80	80	68	30	3	1.0	30	10	63	0.0006	2LC0170-2AA	1.3		
95	140	6600	-	48	-	48	60	95	76	76	35	3	1.0	30	12	73	0.0012	2LC0170-3AA	1.8		
110	225	6300	-	55	-	55	70	110	86	86	40	3	1.0	34	14	83	0.0024	2LC0170-4AA	2.8		
125	345	6100	-	60	-	60	82	125	100	100	50	3	1.0	36	18	103	0.005	2LC0170-5AA	4.7		
140	500	5800	-	65	-	65	90	140	100	100	55	3	1.0	34	20	113	0.007	2LC0170-6AA	5.7		
160	840	5100	-	70	-	70	105	160	108	108	60	4	2.0	39	20	124	0.01	2LC0170-7AA	7.8		
180	1250	4500	-	80	-	80	120	180	125	125	70	4	2.0	42	20	144	0.02	2LC0170-8AA	12		
200	1950	4000	-	85	-	85	130	200	140	140	80	4	2.0	47	24	164	0.04	2LC0171-0AA	17		
225	2300	3600	-	90	-	90	150	225	150	150	90	4	2.0	52	18	184	0.06	2LC0171-1AA	23		
250	3900	3300	46	100	46	100	170	250	165	165	100	5.5	2.5	60	18	205.5	0.11	2LC0171-2AA	30		
280	5500	3000	49	110	54	110	190	280	180	180	110	5.5	2.5	65	20	225.5	0.18	2LC0171-3AA	41		

### Configurable variants <sup>1)</sup>

- ØD1 Without finished bore  
With finished bore
- ØD2 Without finished bore  
With finished bore

### Notes

- Weights and mass moments of inertia apply to maximum bores.

### Ordering example

- N-EUPEX B coupling, size 95
- Part 1: Bore D1 42H7 mm, keyway to DIN 6885-1 and set screw
- Part 2: Bore D2 32H7 mm, keyway to DIN 6885-1 and set screw

Article no.: 2LC0170-3AA99-0AA0 LOX+M0T

<sup>1)</sup> To identify complete item numbers specifying the available finish boring options and – if necessary – further order options, please use our configurators on [flender.com](http://flender.com).

<sup>2)</sup> Version with part 40 (jumbo hub) available on request.

➤ For online configuration on [flender.com](http://flender.com), click on the item no.